



# Garla-Brite®

## PRODUCT DESCRIPTION

Garla-Brite is a non-fibred, asphalt base aluminium roof paint. It provides an exceptionally bright finish with excellent hiding and covering power. Garla-Brite preserves, beautifies and provides a reflective shield over old and new roofing— including metal roofs— and it can be used over a wide variety of other surfaces which require protection from heat, solar radiation, rust and corrosion. Garla-Brite meets and exceeds ASTM D2824 Type I.

## PRODUCT ADVANTAGES

**Saves Energy** - A Garla-Brite application reduces under roof temperature by 8°C or more. As a result, the work load on the building's air conditioning system is reduced by as much as one ton per 139m<sup>2</sup>. Proper interior temperatures can be maintained at lower costs.

**Reduces Roof Deterioration** - Garla-Brite's aluminium finish reflects the sun's ultra-violet rays and reduces their damaging effects on the roof surface. The roof lasts longer and requires less maintenance.

**Improves Building Appearance** - Garla-Brite provides a bright, attractive roof surface which improves the building's appearance. Two coats form a long lasting metallic shield which preserves and protects the roof surface and the roof system below.

**Economical** - Garla-Brite is formulated to provide maximum per litre coverage. Garla-Brite covers the same area as 4 times the standard fibred aluminium coating. Garla-Brite is the ideal top coat for any of Garland's HPR Coating or HPR Roofing Systems.

## APPLICATION

The roof surface should be thoroughly cleaned of loose dirt and dust. Rusted metal should be primed with Garland's Met-Prime Primer. Defective areas should be repaired and the surface must be dry before applying Garla-Brite. Garla-Brite should be stirred thoroughly before being applied with either brush or roller. Brushing in one direction only will insure a bright, reflective surface. In all cases, a two-coat application is recommended. The second coat should be placed perpendicular to the first coat.

- Allow 30 days for Garla-Shield or any emulsion to cure prior to application of Garla-Brite.

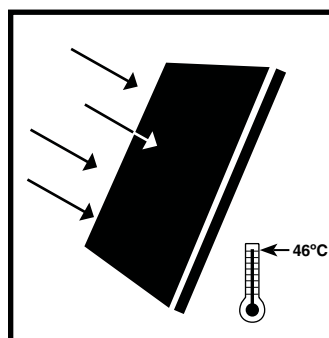

1) Expose a panel of black asphalt roofing to a radiant heat source. Place a thermometer on the opposite side...and watch the temperature go up.

2) Then, expose a panel of the same roofing, painted with Garla-Brite, to the same heat source. A thermometer on the other side of the panel will show more than a 8° difference in temperature.

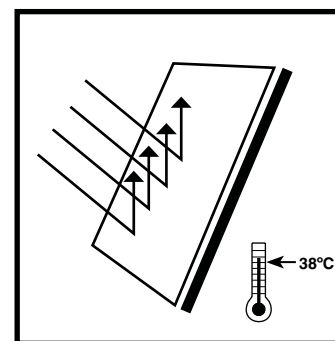

- Allow 90 days for any approved solvent-based product to cure prior to application of Garla-Brite.

## PRECAUTIONS

- Do not apply unless temperatures are at least 10°C and rising.
- Do not apply if there is a threat of rain, dew or temperatures below 10°C forecasted within 24 hours.
- Avoid over working the material which can interfere with the leafing of the aluminium and cause the material to appear bronze or darker than desired.

# Garla-Brite

Technical Data	Garla-Brite
<b>Flash Point</b>	39°C
<b>Density @ 25°C</b>	0.95 g/cm <sup>3</sup>
<b>Non-Volatile</b>	45% min.
<b>Typical Drying Time @ 50% RH, 25°C</b>	Overnight
<b>Service Temperature Extended Exposure</b>	-29°C to 110°C
<b>Resistance to Sunlight</b>	Excellent
<b>Effects of Weathering</b>	Slow erosion
<b>Wet Film Thickness</b>	406 microns
<b>Coverage</b>	
<b>Smooth or Mineral</b>	2 coat application 0.2 l/m <sup>2</sup> per coat
<b>Metal Roofs</b>	2 coat application 0.1 l/m <sup>2</sup> per coat
<b>Packaging</b>	19 l

Eco-Facts	Garla-Brite
<b>VOC</b>	480 g/l
<b>Emittance</b>	33%
<b>Reflectivity</b>	78 %

For specific application recommendations, please contact your regional Garland Technical Manager or the Garland Technical Department.



For more information - visit us at [www.garlandukltd.co.uk](http://www.garlandukltd.co.uk)

**The Garland Company UK, Ltd.**  
 Unit 5, Glevum Works, Upton Street  
 Gloucester, United Kingdom GL1 4LA  
 FAX: 01452 330 657  
 Phone: 01452 330 646  
 Toll Free: 0800 328 5560

*Tests verified by independent laboratories. Actual roof performance specifications will vary depending on test speed and temperature. Data reflects samples randomly collected. A ± 10% variation may be experienced. The above data supersedes all previously published information. Consult your Garland Regional Technical Manager or the Garland Technical Department for more information.*

© 2011 The Garland Company UK, Ltd.

GB 0811